

INSERTION TYPE ELECTROMAGNETIC FLOW METER

Features

- Insertion type
- Suitable for conductive liquids
- Material option depending upon process data
- Local Indication through LCD
- Universal Power Supply 90 to 260V AC, Optional 24V DC
- Simple & cost effective construction
- Unit conversion facility
- Maintenance free
- Communication port (Optional)
- Inbuilt Relay Status output (High / Low / Batch)

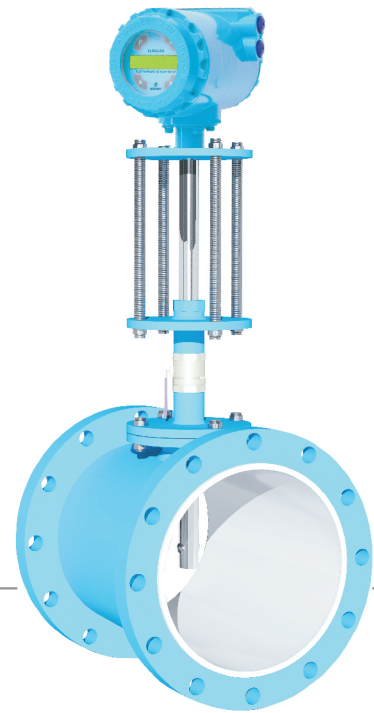

Description

Electronet series ELMAG®-100 are micro-controller based insertion type electromagnetic flow meters specially used for various industrial applications. These flow meters accurately measure the flow rate of conductive liquids &

slurries in closed pipes. Due to its simple & rigid design, the flow meter is an obstruction-less & maintenance-free instrument in place of conventional mechanical flow measuring devices. The use of 'Pulsed DC' technology offers highest ability & better measuring accuracy in the form of electrical signal 4-20mA DC linearly proportional to volumetric flow. The instrument is based on Faraday's law of electro-magnetic induction. A magnetic field is generated by the instrument in the flow tube. The fluid flowing through this magnetic field generates a voltage that is proportional to the flow velocity. Corresponding electrical output is provided with respect to measuring flow range. Along with the flow, pressure of the line is also measured and displayed on 16 x 2 LCD with engineering unit.

Technical Specifications

Media	Liquids (Conductive)
Conductivity	> 5 µs/cm
Viscosity	200 cp max
Line Size	200 NB to 2000 NB
Excitation	Pulsed DC
Type of Output	1) 4 to 20mA DC
	2) 4 to 20mA DC (HART Compatible)
	3) 4 to 20mA DC + Pulse Output
	4) 4 to 20mA DC (HART Compatible) + Pulse output
Display	16 x 2 LCD – 6 Digit for Flow Rate, 8 Digit for Totalizer Flow & 4 Digit for Pressure
Calibration Range	As per requirement
Accuracy	+/- 1% of F.S. (for 20 to 100% flow)
Linearity	+/- 1% of F.S.

Repeatability	+/- 0.5% F.S.
Temperature Coefficient	+/- 0.05% per °C
Process Temperature	85°C max
Process Pressure	16 kg/cm ² max
Material of construction	1) Electrode – SS 316L
	2) Retractable Assembly – MS / SS 304
	3) Wetted Parts – SS 316
Power Supply	Option1 : 90 – 260 V AC, 50 Hz
	Option2 : 24 V DC
Power Consumption	< 10 VA
Response Time	< 2 Sec.
Transmitter Enclosure	Die Cast Aluminum IP66
Process Connections	2" ASA150 flanged, as per table B 16.5
Mounting	Insertion type
Operating Conditions	Temperature -20 to 75°C / Humidity 5 to 95% non condensing
OPTIONAL :	
Communication Output	1) RS 485 supporting MODBUS RTU Protocol
	2) GSM Connectivity
Note :- For process conditions other than above please consult factory.	

Dimensional Details

Line Size (NB)	Flow min (mi/hr)	Flow normal (mi/hr)	Flow max (mi/hr)	Flow (MLD)
200	5.66	113.10	565.50	2.714
250	8.84	176.71	883.55	4.241
300	12.72	254.47	1272.35	6.107
350	17.32	346.36	1731.80	8.313
400	22.62	452.39	2261.95	10.857
500	35.34	706.86	3534.30	16.965
600	50.89	1017.88	5089.40	24.429
700	69.27	1385.44	6927.20	33.250
800	90.48	1809.56	9047.80	43.429
900	114.51	2290.22	11451.10	54.965
1000	141.37	2827.43	14137.15	67.858
1200	203.58	4071.50	20357.50	97.716
1400	277.09	5541.76	27708.80	133.002
1600	361.91	7238.22	36191.10	173.717
1800	458.04	9160.88	45804.40	219.861
2000	565.49	11309.72	56548.60	271.433

Note :

- Typical mounting dimensions for reference
- Standard factory calibration for 0.2 to 2 m/s velocity

Installation Drawing

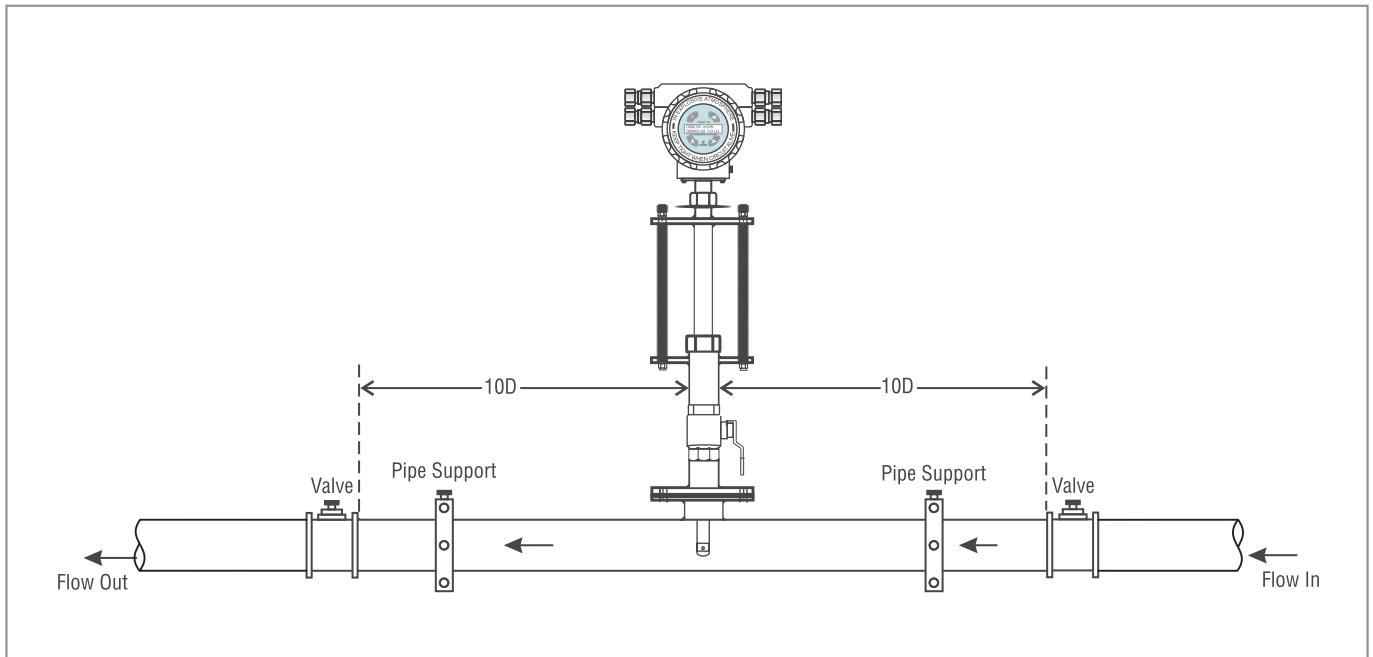

Ordering Information

Sample Order Code : 01M-09A-10C-22A-24B-49B-53B-62A-94C

Parameter	Code	Value	Code	Value	Parameter	Code	Value				
01	Line Size	01L	200 NB	01V	900 NB	22	MOC Electronics Enclosure	22A	Die Cast Aluminium		
		01M	250 NB	01W	1000 NB			22D	SS304		
		01N	300 NB	01AA	1100 NB	24	Power Supply	24A	90 – 250 VAC		
		01O	350 NB	01AB	1200 NB			24B	24 VDC		
		01P	400 NB	01AC	1400 NB	49	Output 1	49A	4 to 20 mA		
		01Q	450 NB	01AD	1500 NB			49B	4 to 20 mA + HART		
		01R	500 NB	01AE	1600 NB			49H	4 to 20 mA + Pulse		
		01S	600 NB	01AF	1800 NB			49I	4 to 20 mA + HART + Pulse		
				01T	700 NB	01AG	2000 NB	53	Communication Output 1	53A	RS 485
				01U	800 NB					53B	RS 232
						53C	GSM				
09	Electronics	09A	Integral					62A	Low		
		09B	Remote					62B	High		
10	Remote Cable Length	10B	5 Meter			62	Relay Output	62C	Batch		
		10C	10 Meter								
		10Z	NA								
						94	Retractable Assembly	94A	MS		
								94C	SS 304		

Note : ▪ Due to our continuous product revisions, design specification and model numbers are subject to change without notice.
 ▪ For GSM communication, SIM card & SCADA viewing software will be in customers scope.
 ▪ Accuracy defined at Lab Conditions. ▪ For other requirement please consult factory.

ELECTRONET EQUIPMENTS PVT. LTD.

Factory Address:

Plot No. 8, (SEZ) Phase 1, Kesurdi MIDC, Khandala, Dist.- Satara Pin: 412 801, Maharashtra, India.

Registered Office:

Plot No. 84, 85, 86, Tiny Industrial Estate, Kondhwa Budruk, Pune-411 048, Maharashtra, India.

+91-20-26931476/2039 ho@eeplindia.com +91-20-26934122 www.eeplindia.com